

User manual Electrical components



The products are CE-Marked, & follows EMC Standard EMC 60601-1-2.

Technical Specifications electrical actuators for Netti wheelchairs

Power: 220V & 110V

Battery: 2Ah

Temperature: -20C - +50C

Service is to be carried out by distributor or qualified technician

Maintenance

The battery should be recharged everyday after use. If the battery is not being used on a regular basis, it must be recharged at a minimum every 3 month.

Maximum charge time: 24 Hours. When the green light is glowing, the battery is fully charged.

For mounting or replacing a battery, see page

Cleaning

Actuators:

The actuators are cleaned for dust and dirt according to need, and should be optically checked for mechanical damage and breakage on a regular basis. The actuators should be wiped with a damp cloth.

Hand control:

The remote control should be wiped with a damp cloth according to need.

Control box:

The battery should be wiped with a damp cloth according to need, the sockets should only be wiped on the inside with a dry cloth.

Charger:

The charger must be wiped with a dry cloth.

Weight

Control box:	1900 Gram
Tilt actuator:	1650 Gram
Recline actuator:	1610 Gram
Foot support actuator:	984 Gram (Pr. piece)
Hand control:	240 Gram
Cable for charger:	20 Gram

Total package: 7388 Gram



Control Box



Foot support



Tilt



Recline

This Procedure includes the following:

- Installing/removing batteries into/from battery boxes
- Connecting battery cables

Warning/Notes

- Make sure POWER to the control box through charger IS OFF before performing this procedure.
- Before ANY actions, make sure all the jack plugs are disconnected - otherwise failure or damage of associated equipment may result.
- NEVER allow any of your tools and/or battery cables to contact BOTH battery terminals at the same time.
- An electrical short may occur and serious personal injury or damage may occur.
- We strongly recommend that battery installation and replacement ALWAYS be done by a qualified technician.
- The control box uses a sealed lead battery (CP1220) which must be recycled or disposed of properly.
- To remove the batteries from the battery box have a cross or flat screwdriver available (PZ, P).

The control box consists of:

(On the Netti Chair the box is mounted upside down compared with the illustration)

- | | |
|---|--------|
| 1. Upper cap | (1pc) |
| 2. Securing sponge | (1pc) |
| 3. Battery (3a,3b) | (2pcs) |
| 4. Separating plate | (1pc) |
| 5. Bottom cap | (1pc) |
| 6. Long wire with black covering | (1pc) |
| 7. Short wire with red or blue covering | (1pc) |
| 8. Long wire with red covering | (1pc) |
| 9. Fixation bolt | (4pcs) |

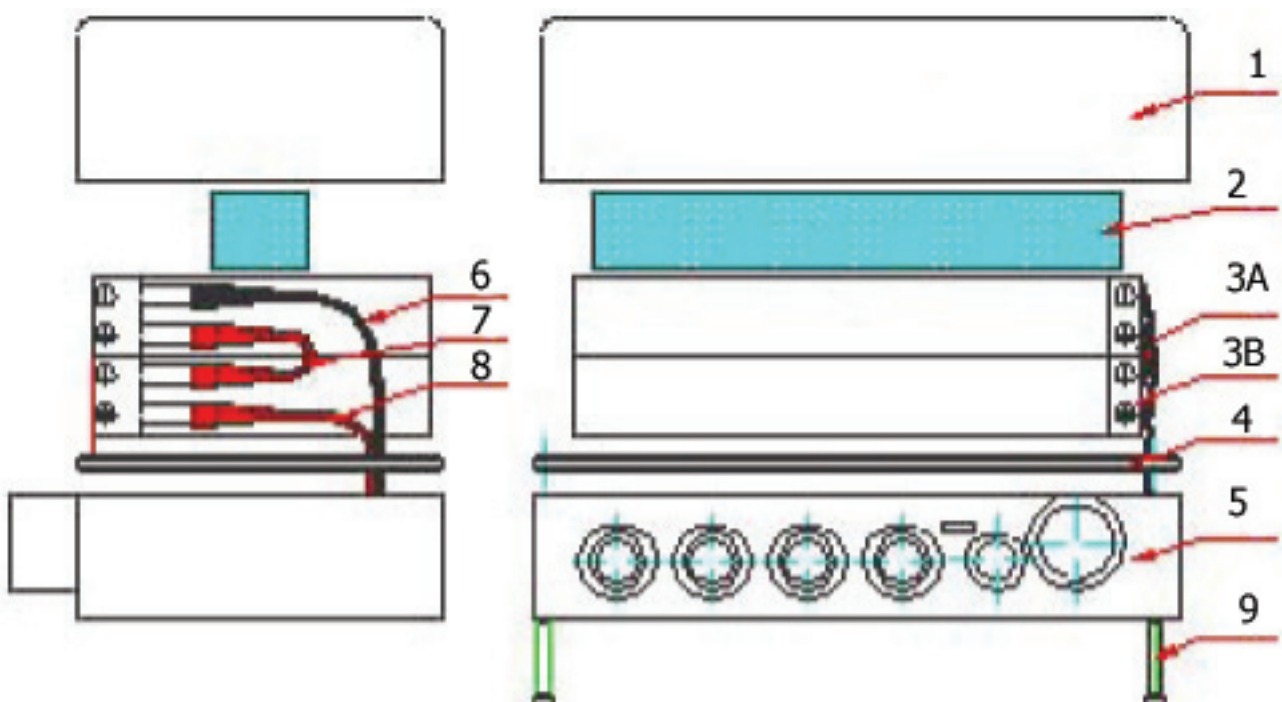

The battery removing procedure.

1. Clean the new battery terminals using a dry cloth
2. Place the control box on upper cap (upside down)
3. Unscrew four fixing bolts
4. Reverse point 2
5. Remove top cap
6. Pull out the battery cables from terminals
7. Take out the existing lead batteries from battery box
8. Clean the new battery terminals
9. Install the new batteries into the battery boxes.
Make sure that the terminals description on the batteries is facing the front side of control box.
10. Connect cables with terminals refer to battery cables connecting instruction. See below.
11. Cover the batteries with upper cup.
12. Replace fixing bolts with screwdriver.

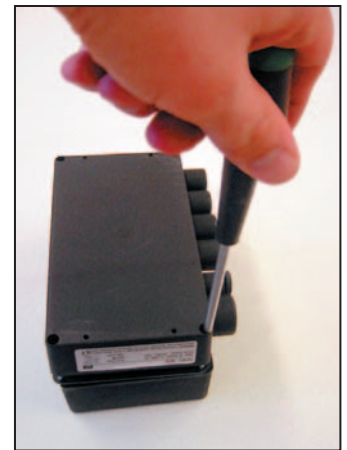

Point 3



Point 6

The battery cables connecting procedure.

Connect battery cables to battery terminals as follows:

1. Negative (-) black battery cable (6) to negative (-) upper battery (3a) terminal
2. Positive (+) red battery cable (8) to positive (+) lower battery (3b) terminal
3. Remaining terminals (centre) connect by using short red or blue cable (7)

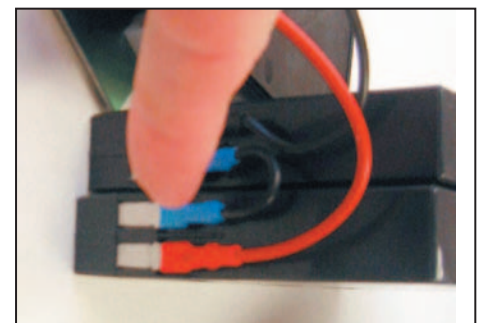
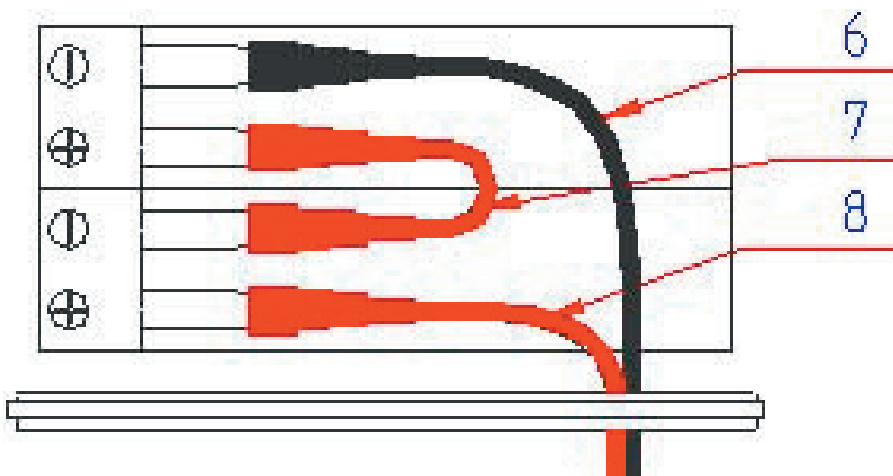

Troubleshooting for Netti el. wheelchair

General

If an actuator is not responding when pressing the control panel:

Check that all contacts to the actuator are securely in position.

It can be an advantage to have the control box set to charge. It will then increase its performance, if the case is that the control box is low on battery.

- If for example a foot support is not working, pull out the plug from the control box, and try another outlet to see if it works.
- If it now works something is either wrong with the outlet in the control box or the control panel. Try with a new control panel. You can also try using another actuator in the outlet for the foot support to confirm that the outlet is broken.
- If it does not work, remove the foot support and pull out the plug for the foot support actuator from the contact bracket attached to the seat frame. Test it in another outlet directly in the control box, or in the contact bracket on the opposite side.
- If it now works, the cable going from the control box to the contact bracket is defect, and should be replaced with a new one. If the actuator is not working in any other outlets, it is defect and should be returned to the supplier.

The same procedure is to be followed for all the actuators.

Troubleshooting for Netti electrical equipment

SYMPTOM	POSSIBLE CAUSE	ACTION TO BE TAKEN
No engine sound or movement of piston rod	1. Actuator is not connected to control box 2. Fuse in control box has blown 3. Cable is damaged	1. Plug the actuator to another outlet in the control box 2. Change the fuse (contact dealer) 3. Send actuator to reparation
Engine is working but no movement of piston rod	Toothed wheel or spindle is damaged	Send actuator to reparation
Engine sound but no movement of piston rod		Send actuator to reparation
Actuator moves too slow or has low yield	1. Too low power supply 2. Voltage drop in cable	1. Recharge battery 2. Send actuator to reparation
Piston rod goes in but doesn't come out	Safety nut has become operative	Send actuator to reparation
Too much power consumption		Send actuator to reparation